

# **Solar Science Workshops**

# **Solar Powered Boat Activity**

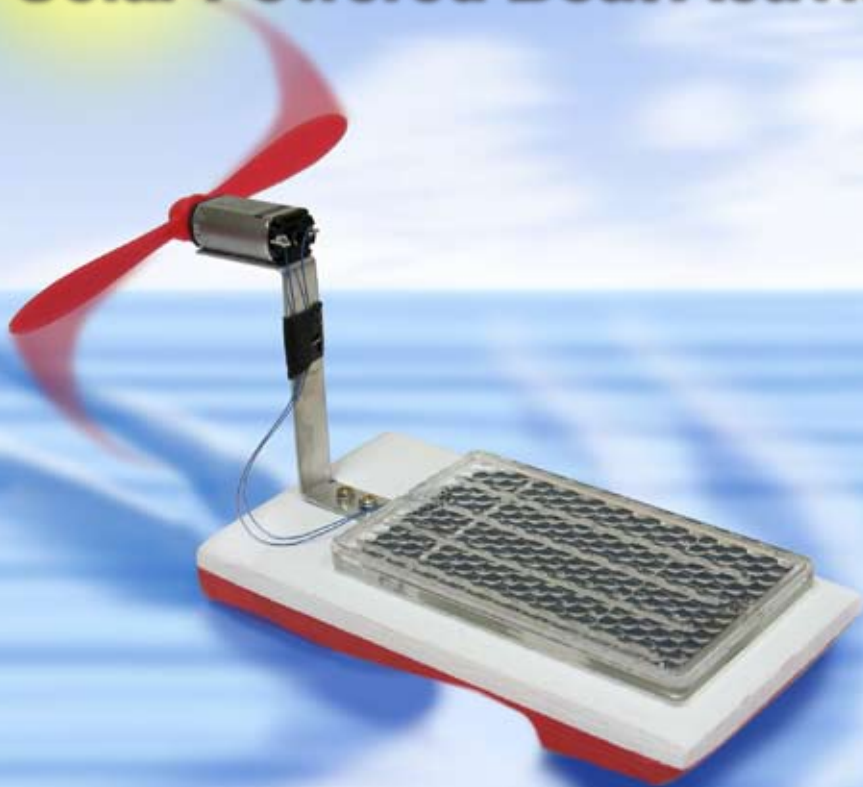

**CHANEY**  
ELECTRONICS, INC.

[www.chaneyelectronics.com](http://www.chaneyelectronics.com)

**SOLAR POWERED BOAT ACTIVITY**  
**STOCK# C6983**

©2010 Chaney Electronics, Inc.

# Table of Contents

<b>Topic</b>	<b>Page#</b>
<b>Table of Contents</b>	<b>1</b>
<b>Introduction</b>	<b>2</b>
<b>Solar Cell Boat Operation</b>	<b>3</b>
<b>Parts Inventory</b>	<b>4-5</b>
<b>Solar Cell Function</b>	<b>6</b>
<b>Solar Cell Identification</b>	<b>7</b>
<b>Activity</b>	<b>8</b>
<b>Experiment 1</b>	<b>9</b>
<b>Experiment 2</b>	<b>10</b>
<b>Experiment 3</b>	<b>12</b>
<b>Experiment 4</b>	<b>13</b>
<b>Experiment 5</b>	<b>15</b>
<b>Experiment 6</b>	<b>16</b>
<b>Constructing the Boat</b>	<b>17-19</b>
<b>Advanced Experiments</b>	<b>20</b>
<b>Tips</b>	<b>Back Cover</b>

## Introduction

Power from the sun can be harnessed in many different ways. Solar energy from the sun is a clean, environmentally safe form of energy that is readily available. It is currently being used in many different ways such as: to heat water and buildings, to power boats and cars, and to provide electricity for homes and even entire cities.

Your Solar Powered Boat uses a high current silicon solar cell to directly power a small electric motor. The shaft of the motor will turn a small plastic propeller when the sun strikes the solar cell. When connected with the correct polarity, the propeller will produce a force of wind which will push the small balsa wood boat forward.

This kit also contains parts and instructions for several scientific experiments. All of the experiments are designed to give a basic understanding of solar cells, magnetism, compass operation, electric DC motors and method of propulsion.

Only simple hand tools, sandpaper, white glue and tape are required. In addition, you may wish to customize and paint your boat. No batteries and no soldering is required.

Please review the parts list and required tools on pages 4-5 and read the solar cell function and identification sections before moving on to experiment 1.

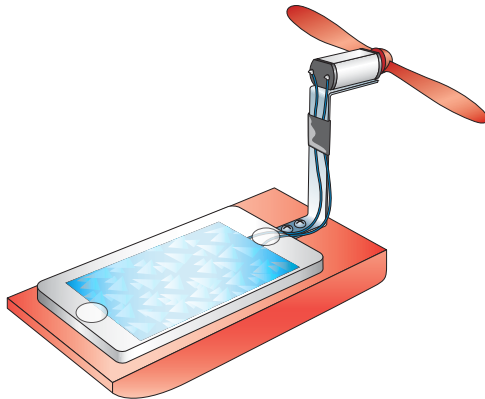

## How Does the Solar Powered Boat Work?

A silicon solar cell basically works by converting sunlight directly into electricity. The electricity that has been produced is used to power a small DC motor, in which a propeller has been attached. The force produced by the propeller as it turns pushes the boat forward.

To go directly to building the Solar Powered Boat skip to page 17.

To learn a brief history of solar cells, the theory behind their operation, and to perform experiments with solar cell operation, DC motors and magnetism continue through all pages of this manual in order.

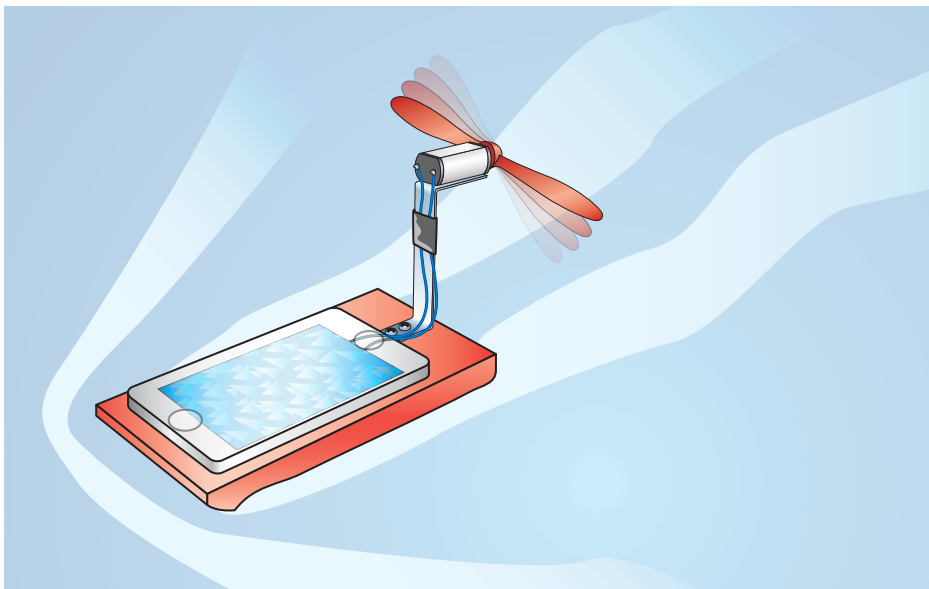

# PARTS INVENTORY

Balsa Wood Block (3" x 6" x 3/4")

Plastic Cased Solar Cell  
(Do Not Drop, Cell is Fragile)

Red Propeller

Compass

2 (N/S) Stickers

1 (+/+) Sticker

Rudder

3 Self Tapping Wood Screws

Motor Mounted to Metal Bracket

2" Piece of Black Tape  
(Placed on Motor Bracket)

2 Round Magnets

18" Piece of Blue Wire

2 Pieces of Peel and stick Foam Pads

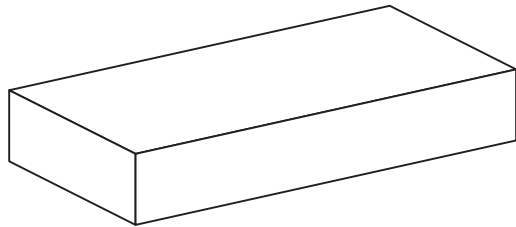

Balsa Wood Block (3" x 6" x 3/4")

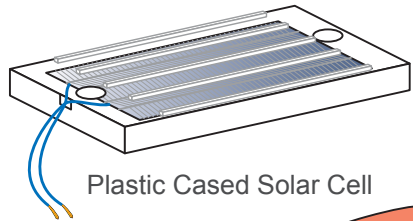

Plastic Cased Solar Cell

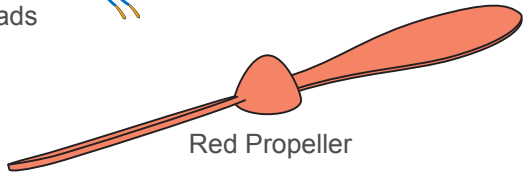

Red Propeller

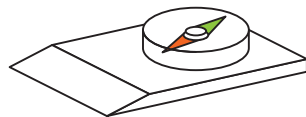

Compass

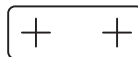

(+ / +) Stickers



2 (N/S) Stickers



Rudder



3 Self Tapping  
Wood Screws

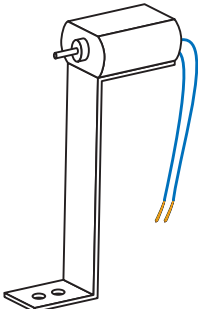

Motor Mounted  
to Metal Bracket

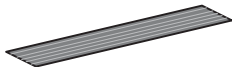

2" Piece of Black Tape  
(Placed on Motor Bracket)



2 Round Magnets

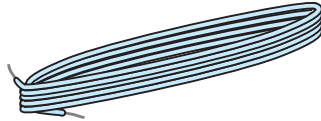

18" Piece of Blue Wire

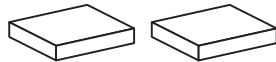

2 Pieces of Peel and  
Stick Foam Pads

## TOOLS REQUIRED

Clear Tape

Standard White Glue

Disposable Cup

Paint Brush

Phillips Head Screw Driver

Measuring Ruler or Tape Measure

Sandpaper

Paint (Optional)

# Solar Cells

The solar cell, also referred to as a photovoltaic cell, was named because the word photo = light and voltaic = electricity. Solar cells can be connected together electrically to form solar panels.

## A Brief History of Solar Cells

A French physicist named Elmond Becquerel first described the photovoltaic effect in 1839. He had discovered that certain materials would produce small electrical currents when exposed to light. The first practical application of Becquerel's discovery was the introduction of selenium cells. Because the conversion of sunlight into electricity was so inefficient in selenium cells, it wasn't a practical source of electrical power. In 1940, a breakthrough known as the Czochraiski process spurred the photovoltaic technology development. This process allowed the manufacture of highly pure crystalline silicon semiconductors to be produced. In 1954, scientists at Bell Laboratories in New Jersey produced the first silicon solar cells. The early applications of these silicon solar cells were to produce electricity for satellites.

## How Do Solar Cells Work?

A silicon solar cell is made of a “sandwich” of two types of silicon semiconductor material, a P-type and an N-type. As photons from the sun strike the top surface of the solar cell, the photons cause electrons in the N-type material to flow from the N-type semiconductor material through the collection bar on the top surface of the cell, then through a load circuit by way of a wire back to the bottom surface of the cell where the electrons combine with “holes” in the P-type material. The process of generating electricity continues as long as the solar cell has sunlight striking it and it stops producing current flow as soon as the light is not striking the cell.

Important facts to know are that solar cells can also be made with the P-type material on top and the N-type material on the bottom, and solar cells can be made from a variety of materials.

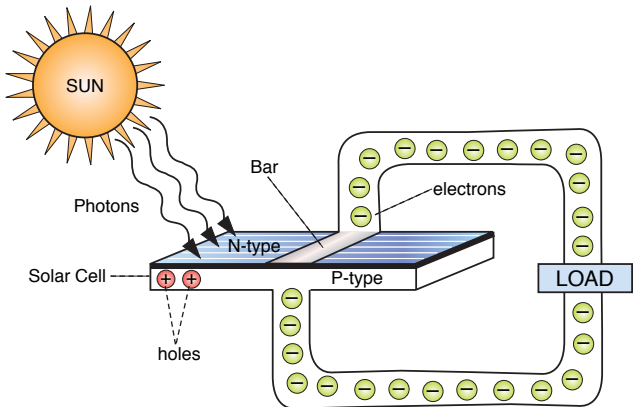

## Solar Cell Identification

Study the solar cell in the plastic case. Look at the solar cell and identify the large and small collection bars (see figure below). Notice how the smaller collection bars are connected to the large collection bar. The bottom surface of the cell is a metallic plated surface and it is the second connection point for a complete circuit. There are several factors that impact the current that a cell will produce but in general **the larger the cell, the larger the amount of current**. Individual silicon solar cells can produce about .45V up to .55V of open circuit voltage when placed in the sunlight, **no matter what size they are**. The solar cell that you are looking at is known as a silicon solar cell. This particular solar cell has a blue anti-reflective surface enabling more of the sun's energy to be converted into electricity. A unique fact about solar cells is that no matter how oddly shaped they are, they will still produce electricity. Since one small solar cell produces very little current and voltage, it's not practical for powering useful devices. Typically multiple solar cells are put together to make solar panels.

**Figure Showing Collection Bars on a Solar Cell**

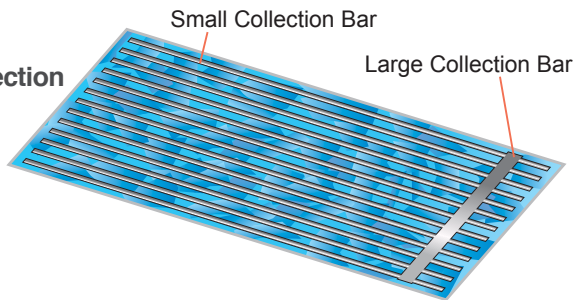

The collection bars are used to collect the electrons. Without the collection bars we would not be able to produce usable electrical current from the cell.

To measure the output from the cell before wires were attached or it was placed in a plastic case, one probe of a meter would be placed on the large collection bar and the other probe would be placed on the bottom metallic surface.

## Activity

Identify the large collection bar and smaller collection bars.

What is the purpose of these collection bars?

Look at the anti-reflective coating on the top of the solar cell.

What is its purpose?

Where should probes of a meter be placed to measure the output of a solar cell before wires are attached?

Solar cells can be very small or large. What electrical characteristic would typically increase if we had a larger cell (Voltage or Current)?

# Experiment 1

## Compass Function

When a magnet is suspended from a fine thread, it is found that the north pole of the magnet will point towards the north geographic pole (magnetic south pole). Scientists do not know for sure when this fact was first discovered. However, historians know that the Chinese were making use of this fact to aid navigation in the eleventh century. The compass provided in this kit uses a magnetized needle with the North pole indicated by an orange tip. The other end of the compass needle is the South pole. The needle rotates freely on a center post so that when the needle is at rest the orange tip points towards the North. Now we will become familiar with a compass.

### PROCEDURE

Use a compass to identify the North direction in your area.

Select the compass from the kit.

Place the compass on a level surface at least 2 feet away from any magnets and let the needle settle until it is motionless. Gently tap on the top of the compass to release the grip caused by friction on the needle, this will give the most accurate direction for North. Once the needle has settled down, the orange pointer is facing North.

Now rotate the compass base until the “N” marker (North) is aligned with the orange needle, notice the green needle is pointed towards the “S” marker (South). Also East and West are identified only by markers on the compass.

### CONCLUSION

You have identified the geographical North. The compass can also be used to identify whether or not an object is magnetic, specific poles on a magnet, and as we will see in another experiment, the compass can be used as a galvanometer to detect current flow and polarity.

## Experiment 2

### Permanent Magnet Function

In this experiment we will study properties of permanent magnets. Permanent magnets do not require electricity to produce a magnetic field. The permanent magnet will attract paper clips, nails and other objects that contain iron. All magnets have two ends or faces called poles. The pole area has the strongest magnetic force. **Each magnet will have a North pole and a South pole.**

This experiment is a simple but important one. We need to identify and mark the poles of 2 round magnets using the (N/S) stickers provided. Gather the compass, both round magnets, and both (N/S) stickers (you will need to cut these in half).

#### PROCEDURE

Put the compass on a level surface at least 2 feet away from any magnets.

Bring one of the magnets near the compass with either flat edge facing the orange needle (North seeking tip). If the orange needle is attracted to the flat side, mark it with the “S” sticker for South. If the orange needle moves away from the flat side mark it with the “N” sticker for North. Repeat this process with the other magnet.

After labeling the poles of each magnet we can observe some of their fundamental characteristics. Try the following and see what happens.

- Bring the North pole of one magnet toward the South pole of the other magnet
- Bring the North pole of both magnets together
- Bring the South pole of both magnets together

#### CONCLUSION

Like poles of magnets repel, and opposite poles attract.

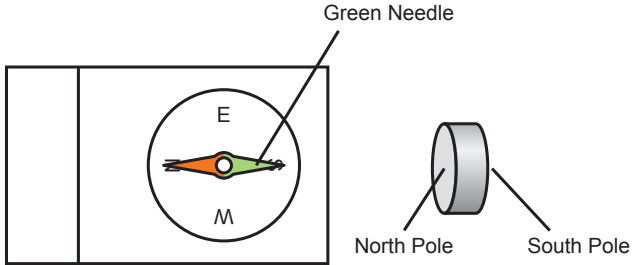

Compass Showing the North Pole of a Magnet

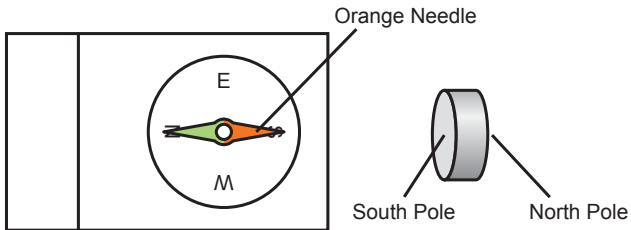

Compass Showing the South Pole of a Magnet

## Experiment 3

### Identifying the Solar Cell's (+) and (-) Leads

In this experiment you will identify and label the (+) lead of the solar cell using the compass to identify current flow.

#### PROCEDURE

Prep the compass by wrapping the 18" long blue wire around it as shown with the white marked lead going over the top of the compass.

After the wire is wrapped around the compass, put a piece of clear tape on the bottom of the compass to hold the wire in place. Set the compass on a level flat surface, then tap and align the compass so the orange needle is pointing North.

Connect one lead of the solar cell to the white marked lead on the wire wrapped around the compass and the other solar cell lead to the remaining wire lead around the compass. Tap the compass to ensure the needle is freely moving while aiming the solar cell towards the sun.

If the compass needle **does not move or slightly moves**, then the solar cell lead connected to the white marked end is (-). You can verify polarity by reversing the leads from the solar cell and re-testing.

If the compass needle **moves at least a 90°**, then the solar cell lead connected to the white marked end is (+).

Label the (+) solar cell lead with the (+) sticker.

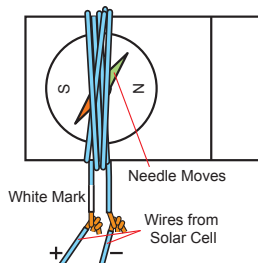
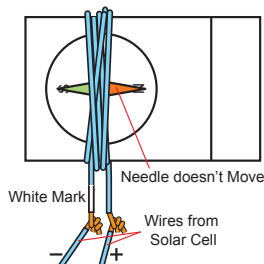
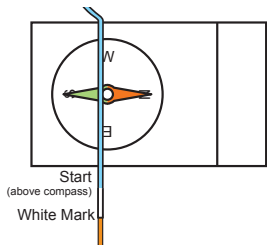

## Experiment 4 Motor Function

In this experiment we will demonstrate that even a small solar cell can power a DC motor. All DC motors work basically the same way. Typically the small DC motor will use two curved shaped permanent magnets inside of a soft iron cylindrical shaped case. One magnet has a north seeking pole for its face and the opposing magnet will have a south seeking magnet face (facing the north seeking magnet face). The shaft on the motor is assembled to a core called an armature. The armature core is made up of slotted iron plates glued together. Around the armature are many windings of wire making up typically 3 separate electromagnets (some DC motors have more). The armature also has a set of 6 contact points called the commutator. Three electromagnetic wire coils on the armature are connected to these contacts (two contacts are needed for each electromagnet coil).

(continued on next page)

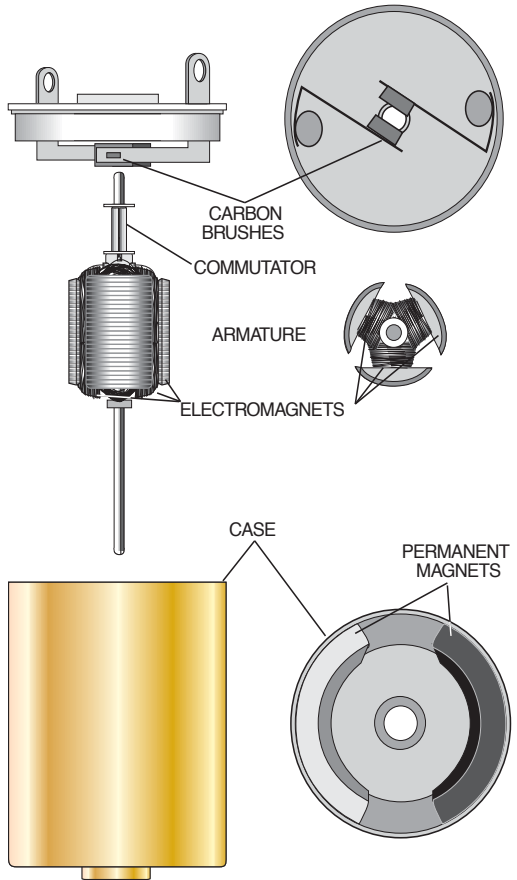

## Experiment 4

### Motor Function (continued)

The DC power from the solar cell that causes the shaft to move is brought into these electromagnets by carbon brushes that touch the commutator. As power is brought into the different electromagnets through the brushes and commutator, the shaft rotates. This occurs because the coils have been wound in a way, that in conjunction with the commutator, the electromagnetic forces reacting with the two permanent magnet fields changes continuously. The constantly changing magnetic fields causes the armature to rotate as long as power is applied.

### PROCEDURE

You can determine if there are permanent magnets inside the motor by bring the compass near the motor body. What happens to the compass needle? Why?

Study how power comes into the DC motor. Does a DC motor have polarity?

Look at the shaft of the motor. What do you think happens to the shaft rotational direction if polarity is reversed?

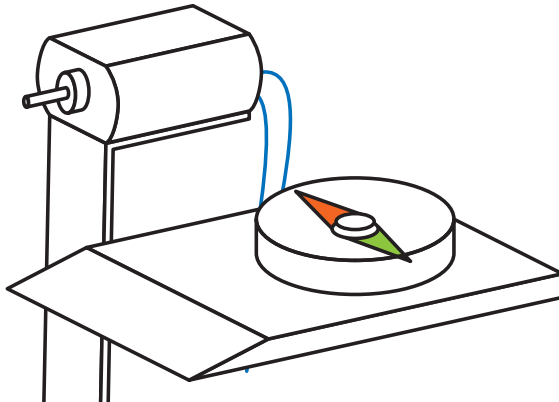

## Experiment 5

### Fan Function

In this experiment we will connect a red propeller to the DC motor to create a fan.

#### PROCEDURE

Carefully press the red propeller over the motor shaft.

Tape the motor bracket to the empty white box the kit came in using clear tape as shown.

Now twist the (+) wires of the solar cell and motor together and twist the (-) wires together as well. The (+) motor wire is pre-marked.

Take the fan and solar cell out into full sunlight and you should feel a breeze from the front of the fan as the propeller spins.

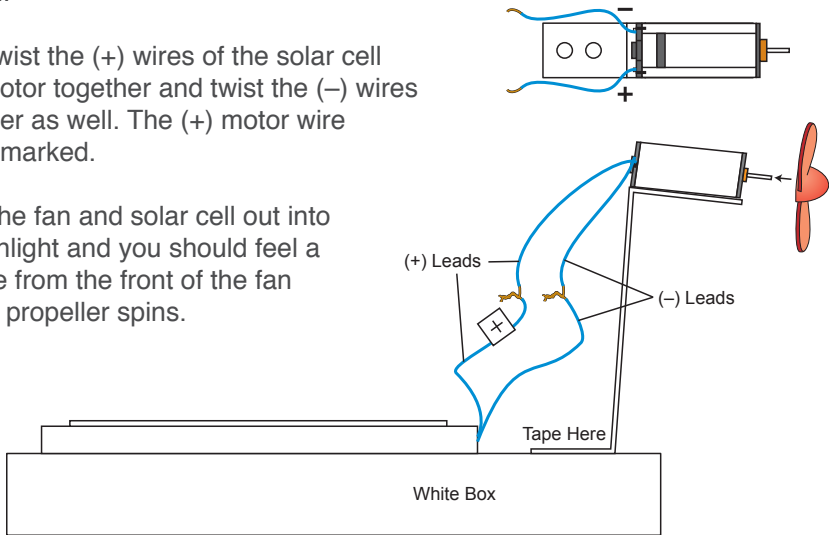

Now reverse the polarity of the leads from the solar cell.

Let sunlight strike the solar cell, and this time the shaft will spin in the opposite direction operating like an airplane propeller instead of a fan. Disconnect the solar cell when finished.

## Experiment 6

### Boat Propulsion

Your Solar Powered boat is basically a flat bottomed boat propelled in a forward direction by a propeller which is driven by a small DC motor. It is similar in operation to airboats as used in the Everglades and Bayou regions of the U.S. One of the major design differences in your solar powered boat is that we use a small metal rudder on the underside of the boat for steering as opposed to large vertical rudders on a full size airboat. Of course there are other minor differences, but this is the greatest difference.

Your solar powered boat operates because of one the basic laws of physics. Sir Isaac Newton was an English mathematician and avid scientist. His Third Law can be simply stated as follows. If an object exerts force on another object, that object will exert an equal and opposite force on the object exerting the force. On your solar powered boat, the solar energy from the sun is converted into electrons, which then powers the small DC motor. This in turn causes the propeller to spin. The spinning propeller pushes air molecules from the front side of the propeller out the back of the boat, in turn, exerting a force that causes your solar powered boat to move forward.

### ACTIVITY

Which law of physics is important for propulsion of the solar powered boat?

What type of full size boat is your solar powered boat similar to?

What is the main design difference between your solar powered boat and the full size boats of this type?

# Constructing the Boat

In this section you will construct the boat

## PROCEDURE

First, decide which end of the balsa wood block is going to be the front and back of the hull. You can sand the sides and a slope into the front of the hull to create a custom streamline look, but the back needs to remain un-altered and the hull must remain at least half an inch thick to float. Wipe off all wood dust before sealing your hull.



To seal your hull, mix 50% water and 50% white glue in a disposable cup. Use a paint brush to coat the entire hull with the sealing mixture. Once the sealant has dried you can custom paint and decorate your hull.

Next, install the fan assembly as shown using two self tapping screws. Measure  $\frac{1}{2}$ " from the back of the hull. Center across the width of the hull at  $1\frac{1}{2}$ ". There are no drilled holes for mounting so you will need to screw the self tapping screws directly into the wooden hull.

*If you over tighten the screws you can apply glue to the screw threads to hold them.*

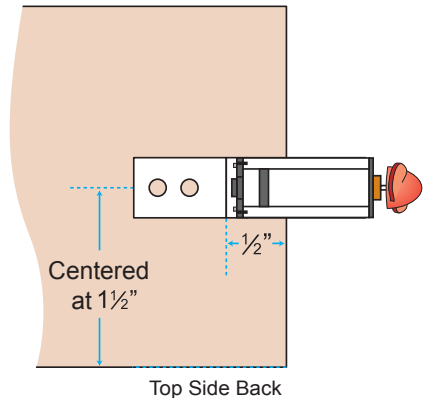

Next, install the rudder on the bottom side towards the back of the hull using one self tapping screw, it should be centered and have about 1/8" distance from the back edge as shown.

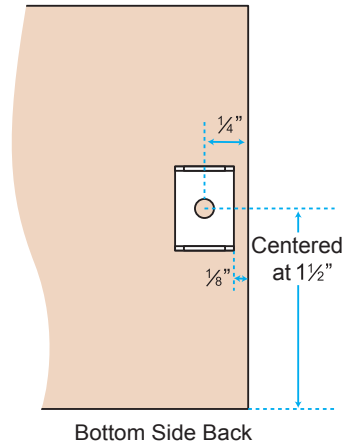

Next, install the solar cell to the hull using the two peel and stick foam pads. Try to center the solar cell and make sure that it is not extending over the edge of the wooden block at all. Make sure the solar cell is oriented so that its wires can make connection with the motor wires. Press firmly on the solar cell to make a solid mount with the peel and stick foam pads.

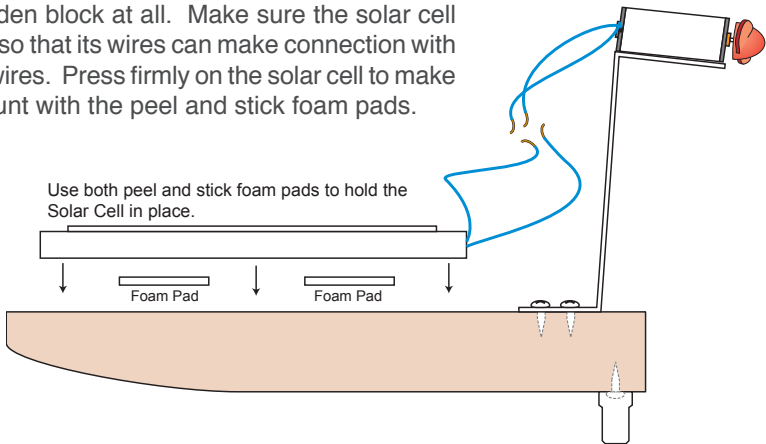

If you performed the previous experiments you have already identified and marked the (+) lead of the solar cell. If you skipped directly to the boat construction, you will need to connect the wires and test the propeller for correct spinning direction.

If you know the (+) and (-) solar cell leads connect them to the motor observing polarity as shown. If you don't know the solar cell polarity, connect the wires between the solar cell and motor by twisting the copper leads together.

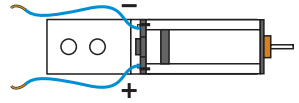

Now test the boat in sunlight. Stop the propeller with a pen or pencil from the boat's left side. The pen or pencil will be above the propeller if the polarity is correct. If the pen or pencil is below the propeller, simply reverse the leads between the solar cell and the motor, then re-test the propeller.

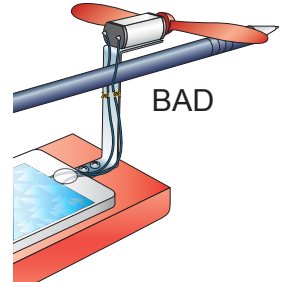
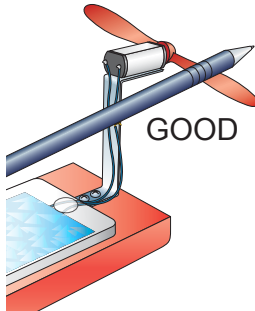

Once you are satisfied with propeller operation, cut two 3/8" long pieces off the supplied black tape and wrap the twisted copper leads to insulate them. *Exposed copper leads will cause shorts and prevent the boat from operating.*

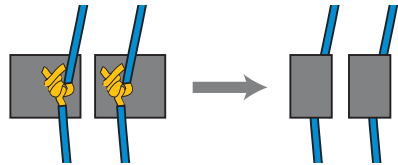

Use the remaining black tape to secure the insulated twisted wires against the motor bracket to prevent them from interfering with the propeller or dragging in the water.

Your solar powered boat is now finished and ready to be taken to the water. Adjust the rudder slightly until the boat moves in straight lines. Try experimenting by slightly angling the rudder to make your boat circle.

See the inside back cover for tips on using your solar powered boat.

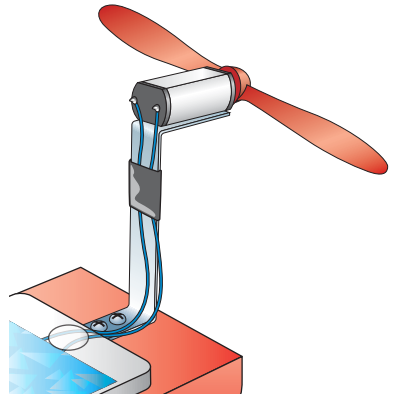

## Advanced Experiments

Try covering half of the solar panel.

What happens to the speed of the boat? Why?

Try different shapes for the hull.

Does a more streamlined front improve speed? Why?

Add weight to the boat without covering the solar panel, sinking the boat or interfering with the propeller.

What effect does this have on boat operation?

## **Tips On Using Your Solar Powered Boat**

**Do not attempt to use your solar powered boat on windy days.**

The wind can overpower the propeller's ability to move the boat forward.

**The propeller does not spin when full sunlight is striking the solar cell.**

Simply re-twist the wire connections for a firmer connection.

**The solar powered boat moves in reverse instead of forward.**

Simply reverse to connection of the wires going from the solar cell to the motor.

**Do not drop the plastic cased solar cell.**

The solar cell is fragile and will likely break if dropped even while mounted in the plastic case.

# We Offer a Variety of Exciting Electronic Courses for Beginner to Advanced Students!



## C6709

### 33 in 1 Deluxe Electronic Exploration Lab

A Great Introduction to Electronic Components, Theory and Circuits!

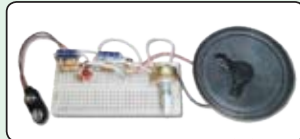

Introduction to Ohm's law, electromagnet circuitry, motor circuitry, transistor circuitry, IC circuitry and 7 segment display circuitry all in one kit!

**100%**  
Re-Useable

**NO Soldering Required!**



**CHANEY**  
ELECTRONICS, INC.

## C6853

### 10 in 1 Solar Energy Exploration Lab

Makes a great introduction to Solar Energy and its uses!

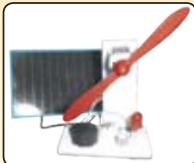

**Lab includes:**  
Breadboard, High Quality Powerful Solar Panel, Resistors, Diode, Motor with Prop, Electronic Buzzer, Flashing LED, Super Capacitor and Wires

**100%**  
Re-Useable

**NO Soldering Required!**



**CHANEY**  
ELECTRONICS, INC.

## C6819

### 25 in 1 Deluxe Magnetism, Motors and DC Circuits Exploration Lab

A Great Introduction to Electronic Components and DC Circuits!

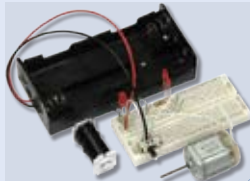

**100%**  
Re-Useable

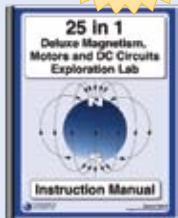

**NO Soldering Required!**



**CHANEY**  
ELECTRONICS, INC.